



RV / Marine WARRANTY & SERVICE GUIDE



Flexsteel manufactures seats for every use:
Residential, Commercial & Vehicle.
Combining smart design with an
unchanging emphasis on quality.

*Flexsteel is truly an American success story
with a proud history and a brilliant future.*

Vision for the Future

*Flexsteel is a respected leader
in the furniture industry
committed to service and innovation.*

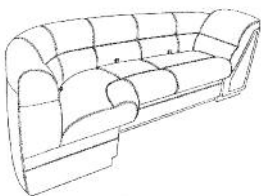

Warranty Information: RV & Marine Seating

Limited Lifetime Warranty

Limited lifetime warranty on Flexsteel metal frame. This lifetime limited warranty is given to the original owner only. Flexsteel warrants the metal frame against failure or breakage under conditions of ordinary use. This warranty does not apply to failure that results from intentional damage, accidents, negligence, exposure or unreasonable use.

One Year Limited Warranty

This one year limited warranty is given to the original owner only and applies to the springs, cushion material, upholstery fabrics, leather and any metal mechanical parts. These items are guaranteed to be free from **manufacturing** defects for a period of one year from the date of purchase.

Filling Materials

Flexsteel warrants to the original owner protection against loss of resiliency of filling materials for one year. Compressing of polyurethane foam with use is **not considered loss of resiliency**.

Ultra-soft pillow backs have sink-in softness thanks to blown-in cushion filling. If your sofa has one of these popular backs, its back pillows should be fluffed occasionally, just as with any other fine pillow, to keep those fibers evenly distributed.

Note: Loss of cushion resilience should not be confused with slight softening and flattening of cushion foam and fibers as a result of normal use and aging. Cushion materials conform to the shape of the user and should not be considered manufacturing defects.

Leather

Flexsteel leather is warranted for a period of one year. No two pieces of leather are exactly alike. Variations and marks occur naturally and are not defects.

Exclusions

These warranties do not apply to furniture intentionally misused, or to damage resulting from negligence, exposure, rental or commercial use, improper cleaning, or other unreasonable use, or to fabric damage or failure due to additional chemical treatment, improper cleaning, or when heavy soiling or abuse is evident. These warranties are not transferrable.

Other rights

These warranties give you specific legal rights and you may have other rights which vary from state to state.

**** Original Owner** is the retail purchaser and only apply as long as they own the product.

Warranty Tag

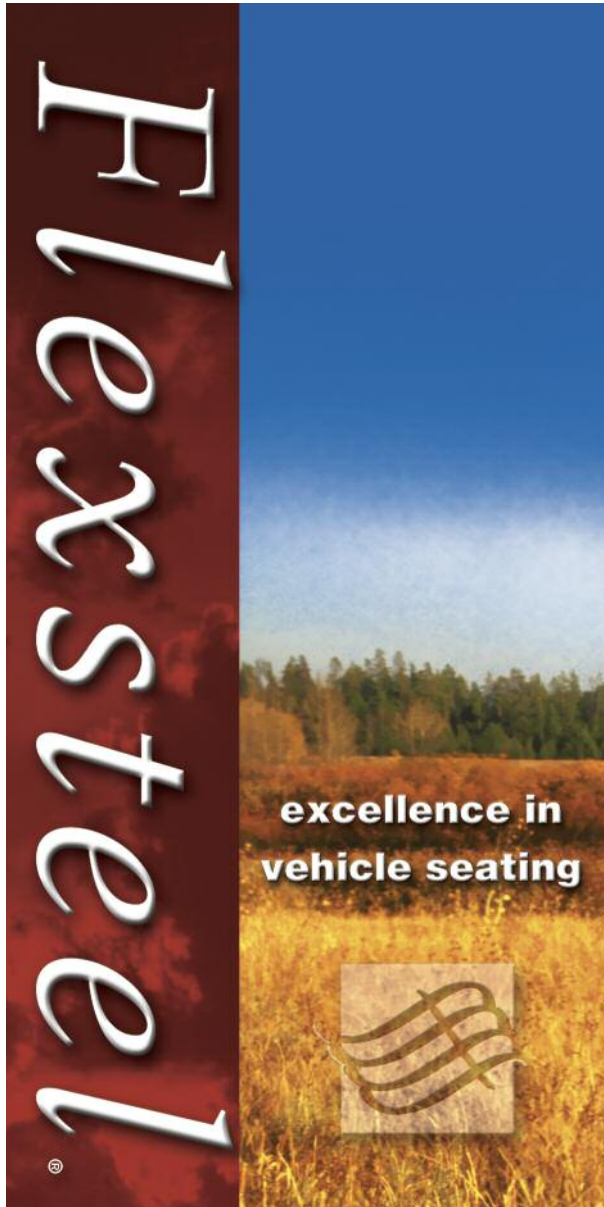

Flexsteel Frame | Lifetime Limited Warranty

This lifetime limited warranty is given to the original purchaser* only. Flexsteel warrants the metal frame against failure or breakage under conditions of ordinary use. All other components are covered to the extent of the manufacturer's vehicle warranty and apply to the original purchaser only.

Warranty Information

In The Event Of Defect — Please contact your dealer for instructions and procedures. The original purchaser will be responsible for packing and transportation charges if necessary.

Other Rights — These warranties give you specific legal rights. You may also have other rights, which vary according to where you live.

Exclusions — These warranties do not apply to furniture intentionally misused, or to damage resulting from negligence, exposure, rental or commercial use, pet damage, improper cleaning, or other unreasonable use, or to fabric damage or failure due to additional chemical treatment, improper cleaning, or when heavy soiling or abuse is evident. Fabric fading, pilling, shrinkage, stretching, fabric wearability and colorfastness are not covered by this warranty. *These warranties are not transferable.*

Caution — Children should not be allowed to play on or operate motion products. The leg rest of a recliner folds down on closing and could result in injury to a child. Always leave unoccupied chairs in closed upright position. Smoldering smoking materials or flames can cause urethane foam to burn, creating upholstered furniture fires.

***Original Purchaser** — *These warranties are given only to the original retail purchaser and only apply as long as the original purchaser owns the product.*

Cleaning & Care

Leather — Flexsteel recommends cleaning your leather rv and marine furniture with mild soap and water only.

Ultraleather / Optimizeather — Spot clean with mild soap or an ordinary household cleaner, such as Fantastik or 409. Remove any residue with a damp cloth. Can be disinfected with a 5:1 non-chlorinated bleach solution.

Fabric — Vacuum or brush lightly to remove soil.

Warranty Process: Field Repair

In the Event of a Needed Repair

Report any defects promptly to your RV/Marine Dealer or Vehicle Manufacturer with proof of purchase by supplying a copy of the Flexsteel Frame ID tag. This tag can be found folded and tucked under the seat portion of the furniture between the spring and foam, other styles may have this id tag fastened to the front panel or footrest when available.

This frame id tag will provide Flexsteel with the needed information to provide you with the best solution to your concerns. Required information for the repair will be the FLEXSTEEL style/description, fabric numbers, year, make/model of vehicle, and owners date of purchase and email photos of the issue and copy of the Flexsteel frame id tag.

The Vehicle Manufacturer will contact Flexsteel for a repair authorization. A repair authorization number will be assigned for the requested repair along with a time allowance. After the repair is completed, the replaced part, along with the labor claim must be submitted to the manufacturer. The manufacturer will then file the claim with Flexsteel. The claims will be processed within 30 days. Transportation costs incurred with the repair will be the responsibility of the original owner.

All required documents must be presented when filing labor/warranty claims to Flexsteel. We reserve the right to deny claims not following proper procedures. Authorization number does not guarantee claim will be paid if abuse is present.

DEALER NO.	ORDER/SEQ NO.	STYLE/DESCR
SCHEDULE DATE	DPC NO.	FABRIC NO.

GENUINE
TRADEMARK REGISTERED



Flexsteel
America's Seating Specialist
www.flexsteel.com

SPRING UNIT
MANUFACTURED
IN DUBUQUE, IA USA

Warranty Process: Repair Returns/Credit Returns

Credit Returns

Contact our customer service department for your return authorization. A return RIR form will be issued and a copy will be emailed or faxed to your attention. We will require all needed information from the Flexsteel Frame ID tag in order to process your request for return credit. When available a Flexsteel truck will pick the product up for return to Flexsteel. Any parts returned other than a Flexsteel truck will be the responsibility of the original owner. Credit will be issued upon the inspection of the product or parts. If abuse is evident no credit will be issued.

Repair Returns

Contact our customer service department for your return authorization. A return RIR form will be issued and a copy will be emailed or faxed to your attention. We will require all needed information from the Flexsteel Frame ID tag in order to process your request for the repair. Repairs will be made in a timely manner and returned to you when completed.

Parts Returns

Parts returned to Flexsteel for credit must have prior authorization. A repair authorization for the replacement part must have been issued prior to the repair. All shipping incurred with this return are the responsibility of the original owner. A labor claim must accompany the parts return with a copy of the sublet repair or claim will be denied.

Note: All repairs or returns must have prior authorization by contacting the Customer Service Department at the numbers listed below. All product and parts are subject to evaluation. Proper carton/packaging is required for all returns. Flexsteel reserves the right to deny claims not following the proper procedures.

Dubuque, Iowa

Colleen Kafar
563.585.8205
ckafar@flexsteel.com

Dubuque, Iowa

Lisa Bauer
563.585.8356
lbauer@flexsteel.com

Riverside, California

Jennifer Baer
951.354.2440 ext. 228
jbaer@flexsteel.com

Warranty Process: Repair Returns/Credit Returns



RETURNED ITEM REPORT

DRIVER'S NAME _____ ZONE NO. _____ TRAILER NO. _____ DATE _____ PICK-UP ORDER/DEL. RECEIPT NO. _____

CHECK PROPER BOX
 REPAIR REFUSED BY DEALER RAW MATERIAL STYLE _____ DESCRIPTION _____ FABRIC NO. _____

DEALER NAME: _____
 STREET ADDRESS: _____
 CITY, STTE, ZIP CODE: _____

INDICATE HOW ITEM RETURNED:
 WITH CUSHIONS WITH PILLOWS WITH LEGS
 WITHOUT CUSHIONS WITHOUT PILLOWS WITHOUT LEGS

FOR RAW MATERIALS ONLY IF PIECE REFUSED ENTER ORDER NO. _____ REMARKS: _____
 POUNDS CARRIED: _____

SPECIAL INSTRUCTIONS: _____ *FOR OFFICE USE ONLY* _____ PIECE IDENT. TAG _____

209104

OFFICE COPY

RV & Marine Seating: FAQs

Can I buy RV/Marine furniture directly from Flexsteel?

Flexsteel furniture is only sold through authorized Flexsteel furniture dealers. Use our on-line retailer locator to find the authorized dealer nearest you.

How can I get a price on Flexsteel RV/Marine furniture?

Retail selling prices are determined by each Flexsteel RV/Marine dealer. We encourage you to contact your nearby RV/Marine Dealer for pricing information. Use our on-line retailer locator to find the Flexsteel dealer closest to you.

I need to purchase fabric to match my furniture. How do I go about that?

Please contact your local RV/Marine Dealer to check the availability of fabrics and they will place your fabric order with Flexsteel.

How do I know if a necessary repair is covered by the Flexsteel warranty?

Report any product issues to your dealer or manufacturer promptly with proof of purchase. They will help you determine if a repair is covered under warranty and will make necessary arrangements.

Can I get a product catalog?

All catalogs are available from the Flexsteel website and can be printed on high or low resolution printers. Hard copy brochures are available through your local Flexsteel RV dealer or by filling out the information on the Flexsteel web page. www.flexsteel.com/vehicle-seating/products

Can I get fabric swatches?

To help you make the best fabric decision, we encourage you to work with your RV/Marine dealer to see the variety of fabric colors and options available. Your dealer can help guide you to your final decision by explaining the important differences in fabric wearability and cleanability before you make your final decision.

My Flexsteel furniture is in need of cleaning. How do I know what products are safe for my fabric or ultraleather?

Flexsteel only suggests a mild soap and water solution for daily cleaning of ultraleather. It is not recommended to use any type of leather protection that could cause the material to crack or peel. Fabric furniture should be vacuumed as needed to insure long-lasting results.



Ultraleather™ Collection

The Ultraleather™ Collection was formulated with a unique strengthening technology. Designed for longevity, its exceptional durability and effortless cleaning make it the ideal surface for high wear applications.

Genuine Ultra Surfaces:

- Exceed heavy duty abrasion standards
- Are scratch, nick, and blemish resistant
- Stay comfortable in all climates
- Meet international environmental standards
- Clean effortlessly with soap and water
- Lift most stains with Fantastik® and Formula 409®
- Can be disinfected with a 5:1 bleach solution

Care Instructions:

STAIN	MILD DETERGENT
Ketchup, Mayonnaise	•
Butter, Salad Oil	•
Red Wine, Liquor	•
Coffee, Tea, Coca-Cola®	•
Make-Up, Face Cream	•
Machine Oil	•
Urine, Blood	•
Steak Sauce, Soy Sauce	•
Chocolate	•
Milk	•



ULTRA SURFACES. ULTRA RELEVANT.
For samples visit us online at
ultrafabricsllc.com or call 914.460.1730



Flexsteel Adjustable Arm

Notice: This Ergo-Flex leveling arm remains in its adjusted position, even when the arm is raised and again lowered, until this locked position is changed.

1. To raise the arm locked position

Lift the fingertip adjustment lever, then raise the end of the arm to the desired position and release lever to relock.

2. To lower the arm locked position

Lift the fingertip adjustment lever, then lower the end of the arm to the desired position and release lever to relock.

Patented Flexsteel Innovation



Ergo-Flex Leveling Arm System

- adjusts arm position for reclining comfort
- installs in any Flexsteel reclining bucket seat
- activates by fingertip release mechanism
- rotates from sitting position



Arms rotate a 120 degree arc, accessible from any back position from upright to fully reclined. Your comfort adjustment is retained when arm is folded upright to exit seat. When you return to your seat and fold the arms forward, they will stop at the previously selected position.

Fingertip Adjustment

Low profile toggle switch adjusts and locks the desired comfort position in place. Lift switch, move arm to desired position, release to lock.

Flexsteel Bucket Seat Arm Removal & Installation Instructions

(Seats Manufactured after June 1, 2000)

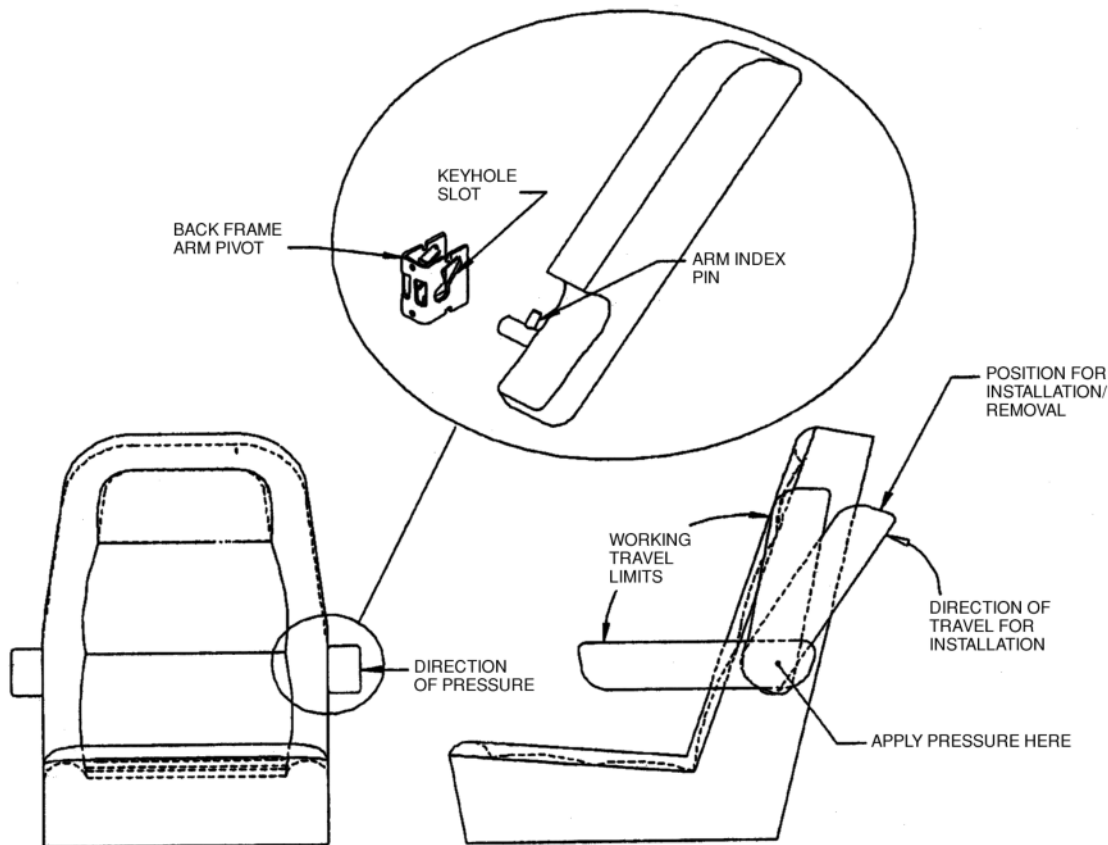

To Remove Arm:

1. With arm in its upper working limit position, apply light rearward pressure on the end of the arm while pushing inward (approximately $\frac{1}{2}$ inch) on the pivot area of the arm as shown.
2. Rotate the end of the arm rearward until it reaches the approximate removal position shown. Release and then with slight outward pressure, rotate the arm to allow the index pin to align with the keyhole slot on the back frame arm pivot. Once the pin and slot are aligned, pull outward on the pivot area of the arm to remove the arm.

Arm Installation:

1. Align the arm index pin with the keyhole slot on the back frame arm pivot (see removal/installation position) and at the position shown, push the arm inward, until the arm pin clears the keyhole slot and can be freely (do not force) rotated forward.
2. Once the arm has been rotated forward, release the inward pressure on the pivot area of the arm. Rotate the arm downward until it stops.



Flexsteel[®]
Excellence in Vehicle Seating

PO Box 877 • Dubuque, IA 52004-0877
Ph: 563.556.7734 • Fax: 563.583.2712

PO Box 4607 • Riverside, CA 92514-4607
Ph: 951.354.2440 • Fax: 951.785.5977

Repair Time Allowances

Flexsteel Industries Inc.

Repair Time Allowances

BUCKET SEATS

	Hours	Minutes
1. Remove & re-install	0.5	30
2. Remove & replace pedestal	0.5	30
3. Replace slide tracks	0.4	24
4. Recover seat — not glued	0.9	54
5. Recover back — not glued.	0.9	54
6. Replace seat poly	1.5	90
7. Replace back poly	1.5	90
8. Remove / replace arm (qty 1).	0.2	12
9. Recover arm (qty 1)		
a. Tailored type — non-adjustable	0.5	30
b. Tailored type — adjustable.	0.7	42
c. Pullover type — non-adjustable	0.2	12
d. Pullover type — adjustable.	0.4	24
10. Replace arm metal		
a. Non-adjustable.	0.1	6
b. Adjustable	0.5	30
11. Headrests		
a. Remove / replace	0.1	6
b. Recover — Removable.	0.5	30
c. Re-attach headrest clip strips	0.1	6
12. Replace skirt		
a. Not sewn on.	0.3	18
b. Sewn on	1.0	60
13. Replace Button (First button, including gain access to do)		
a. In-back (one side, prong or fastuft)	0.8	48
b. In-back / out-back (button to button).	0.1	6
c. Seat — prefilled	0.8	48
d. Seat — non-prefilled.	0.4	24
e. Additional buttons after first		1m. ea.
14. Replace mechanism handle0.1	6
15. Re-sew seam (per inch)	0.1	6

Repair Time Allowances

Flexsteel Industries Inc.	Repair Time Allowances	
BUCKET SEATS (continued)	Hours	Minutes
16. Replace remote control cables		
a. Pedestal or track cable within seat	0.5	30
17. Remove / replace bolted-on recliner mech.(return original)	1.2	72
18. Remove / replace seat heater	1.4	84
19. Remove / replace 6-way power unit.	0.5	30
20. Replace power lumbar bladder	0.7	42
21. Remove / replace footrest motor	0.8	48
22. Remove / replace footrest cables	0.5	30
23. Replace 6-way power switch	0.1.	6
24. Repair bent tab on armrest bracket	0.5	30
25. Replace seat heater switch	0.1.	6
26. Replace footrest worm gear.	1.0	60

INTEGRATED BUCKET SEATS

(items different than normal bucket seats)	Hours	Minutes
1. Remove / reinstall integrated bucket seat	0.6	36
2. Remove / reinstall integrated pedestal	0.7	42
3. Remove / reinstall integrated power unit	1.2	72
4. Remove / reinstall integrated seat cover.	1.3	78
5. Remove / reinstall integrated back cover	1.2	72
6. Remove / reinstall integrated hard skirt	0.2	12
7. Remove / reinstall seat belt buckle & retractor	1.0	60
8. Remove / reinstll footrest worm gear	1.6	96
9. Remove / reinstall switches	0.1.	6
10. Remove / reinstall swivel cable	0.5	30

Note: Times need to be combined past #1

power unit = 0.6 + 0.7 + 1.2 = 2.5

seat cover = 2.5 above + 1.3

back cover = 2.5 above + 1.2

Repair Time Allowances

Flexsteel Industries Inc.	Repair Time Allowances	
SOFA	Hours	Minutes
1. Remove & reinstall bed	0.7	42
2. Recover front panel		
a. Complex panel	0.7	42
b. Without center seams, related poly (fiber)	0.4	24
3. Rework front panel (not full cover)	0.4	24
4. Remove / replace seat or in-back pillow-pre-fill (per sect)	0.3	18
5. Re-sew seam (per inch)	0.1	6
6. Remove / replace bolted-on front panels		
a. CS styles	0.4	24
b. MB styles	0.2	12
7. Remove / replace bolted-on arms (EB, MB, LS, CS)	0.5	30
Remove / replace bolted-on arms (DE)	0.3	18
8. Recover arm:		
a. Simple slip over	0.5	30
b. Upholstered (panels, pleating)	1.0	60
c. With trim nails (remove, replace) Add		0.5 m/nail
9. Headrests		
a. Remove / replace only	0.1	6
b. Recover	0.7	42
c. Re-attache headrest clip strips	0.1	6
10. Replace buttons — First button	0.4	24
Additional after first		1m. ea.
11. Recover — seat, back or third section or versa-flex extension	0.5	30
12. Replace — seat, back or third section	0.7	42
13. Replace MB seat cover	1.0	60
14. Replace MB base cover	0.8	48
15. Replace MB seat base poly	1.5	90
16. Replace CS style unit	1.0	60
17. Remove / replace seat or back frame poly	0.7	42
18. Remove / replace base motor	0.8	48
19. Replace third section zipper (with tear down)	1.0	60
20. Adjust bed lock	0.1	6
21. Remove / replace bed lock	0.3	18
22. Recover zippered seat, back (wall beds)	0.3	18
23. Replace air bladder	0.1	6
24. Replace valve	0.3	18

Repair Time Allowances

Flexsteel Industries Inc.

Repair Time Allowances

J-LOUNGE (Love Seat)

Hours Minutes

1. Remove / reinstall (J-LS)	0.8	48
2. Disassemble / reassemble	0.6	36
3. Recover seat	0.5	30
4. Recover back — without center arm	0.8	48
with center arm	1.0	60
5. CRT		
a. Disassemble and reason	0.4	24
b. Remove / replace seat cover	0.4	24
c. Remove / replace back cover	1.2	72
6. Booth-type dinette		
a. Recover seat	1.0	60
b. Recover back	1.5	90
c. Recover removable pillow	0.2	12
d. Remove, reinforce filler poly	0.4	24
e. Recover filler	0.4	24

Repair Time Allowances

Flexsteel Industries Inc.

Repair Time Allowances

RECLINERS

	Hours	Minutes
1. Remove / replace recliner in vehicle	0.2	12
2. Recover footrest	0.5	30
3. Replace remote cables	0.5	30
4. Recover mid-otto panel	0.3	18
5. Replace seat cover	1.5	90
6. Replace back cover	0.7	42
7. Recover arm	1.0	60
8. Remove / replace arm	0.5	30
9. Remove / replace mechanism unit	1.2	72

CHAIRS

	Hours	Minutes
1. Remove / reinstall	0.2	12
2. Replace seat cover	0.7	42
3. Replace back cover	1.2	72
4. Replace seat poly	1.3	78
5. Replace back poly	1.7	102

ROCKER / SWIVEL CHAIR

	Hours	Minutes
1. Remove / reinstall unit	0.2	12
2. Replace base	0.5	30
3. Recover seat	1.0	60
4. Recover in-back cover	1.0	60
5. Replace arm cover	1.0	60
6. Replace seat or in-back poly	1.2	72
7. Replace complete cover	2.0	120

